

## **Pivatic Punching Centers utilize coil for automated manufacturing at high speed.**

**Simple set up, exceptional manufacturing speed and substantially lowered material costs are just some advantages that add to the bottom line.**

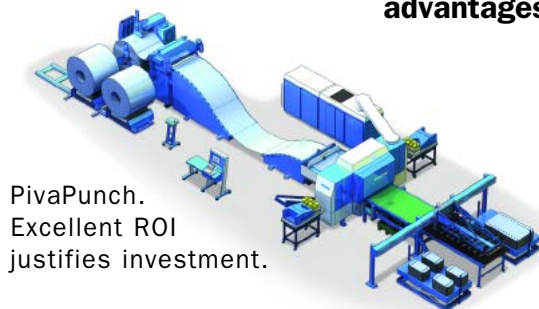

PivaPunch.  
Excellent ROI  
justifies investment.



# **PIVATIC**

An Ursviken Group Company

# PivaPunch. Punched parts, made straight from coil with minimum handling, create a leap in productivity for both small and large manufacturers.

PivaPunch is the most efficient and versatile coil punch on the market.

Smaller manufacturers will find it useful to be able to run smaller product series back-to-back or nested together fully automatically. Larger manufacturers will find PivaPunch's better cycle times more profitable. PivaPunch is non-operator dependent, making it possible to run 24/7 with minimal assistance.

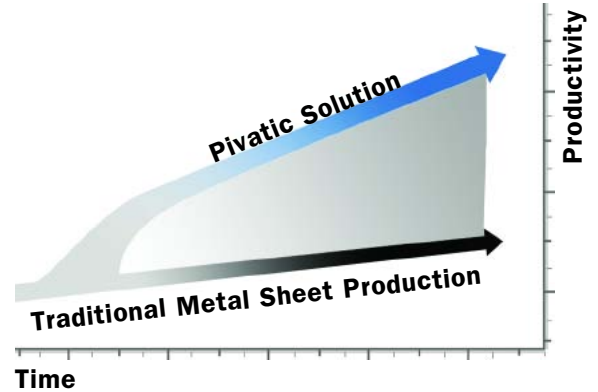

PivaPunch increases productivity more than any other punching method.

## A long line of excellent features and advantages promises quick ROI and long lasting profitability.

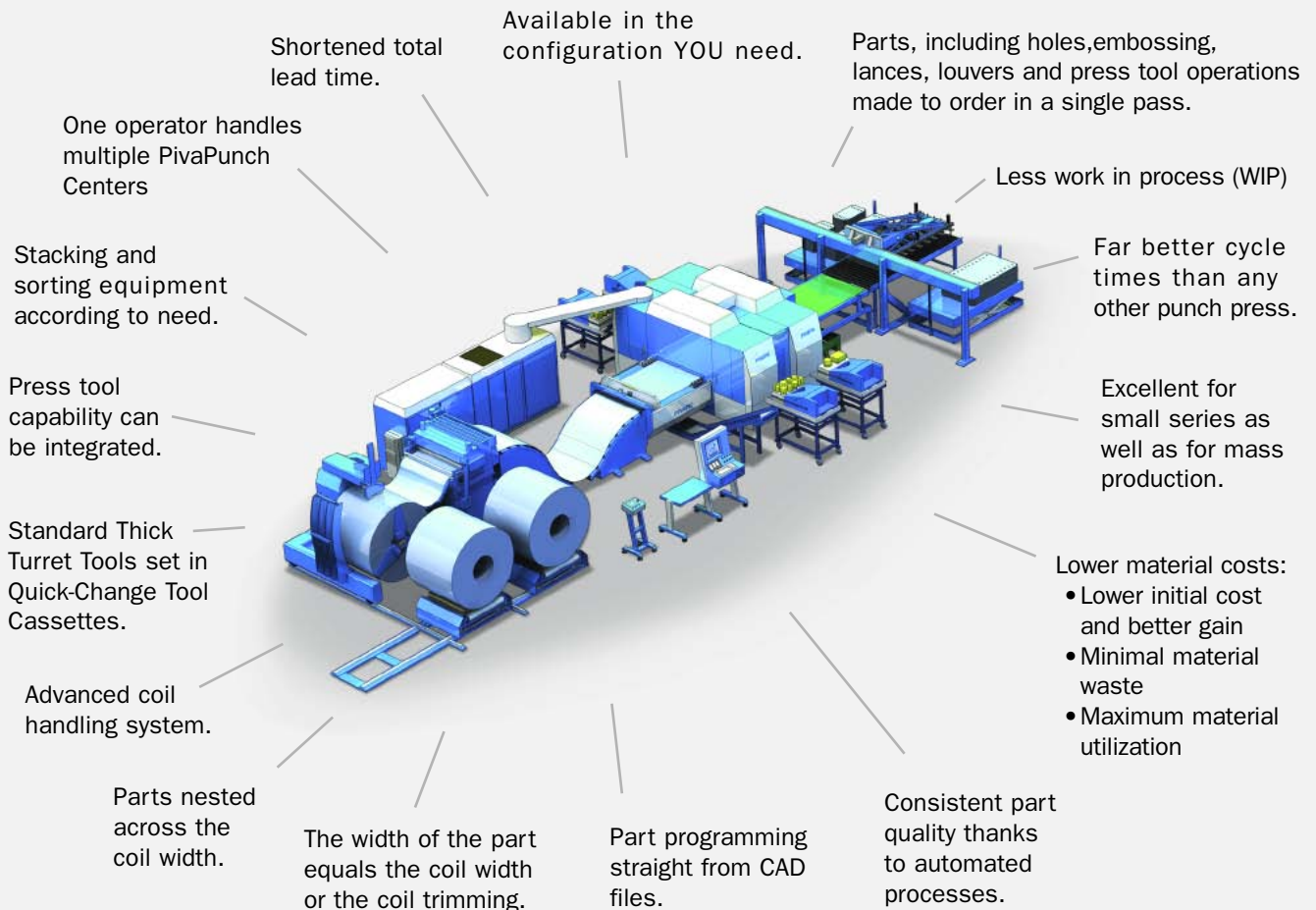



**Industries that use PivaSystems:**

Office Furniture, Heating & Ventilation, Air Conditioning, Domestic Appliances, Shelving, Lighting Fixtures, Electronics, Vehicle, Accessories, Telecommunications, Subcontracting, Enclosures

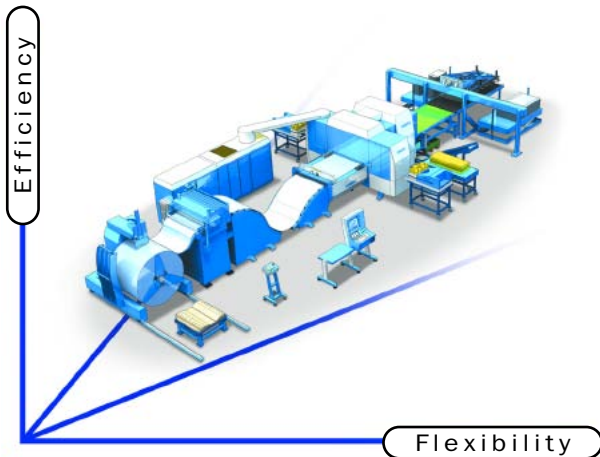

**PivaPunch is more efficient than any other punching method because it makes parts, including press tool operations, made to order in a single pass.**

PivaPunch is more **efficient** than any other punching method because it works straight from coil fully automatically. PivaPunch is more **flexible** than other punch methods because it uses an advanced and freely programmable CNC coil punch system.

**PivaPunch benefits:**

- 100% of time is actual punching
- No tool change time - all tools active
- Double Tool Punch Feature, two holes or corners of a symmetrical pattern punched at the same time
- Strip fed from hit-to-hit non-stop
- No loading time with continuous coil feeding
- Stacking of punched blanks during punching time
- No dead punching zones

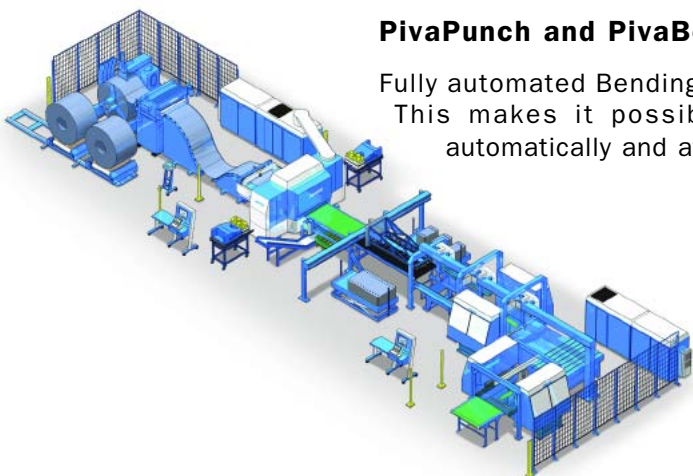

**PivaPunch and PivaBend Centers.**

Fully automated Bending Line can be integrated with Pivatic Punching Center. This makes it possible to produce finished parts straight from coil automatically and at a high production speed.



# The strength behind PivaPunch is in the combination of

## Pivatic Punching Center for Coils in basic configuration includes:

- Coil handling equipment is selected per customer's need.
- Punching station TT capable of punching, nibbling, embossing and cut-to-length (more about the various stations on the next spread).
- Automated stacking equipment configured to customer's need.  
A stacker makes it possible to run PivaPunch unattended.

## Coil handling systems for various applications.

PivaPunch can be configured with various decoiler options enabling different levels of speed and automation.

- The decoiler picks up the coil from a stand.
- Two coil cars for fast coil change.
- Multi-station coil storage for long independent production.

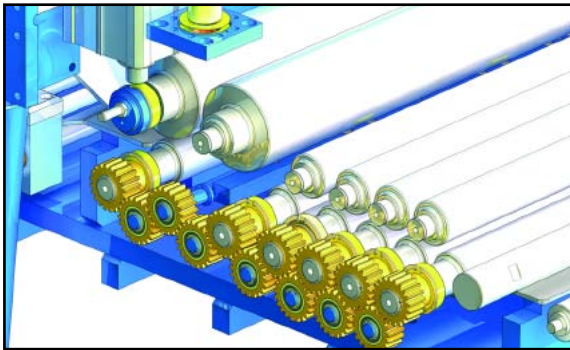

## Coil tension is eliminated in a straightener.

- Thoroughly calculated and tested roll diameter - distanced for optimum results
- Upper part adjusted as a block on entry and exit sides
- All straightening rolls are supported
- Drive on all lower rolls for smooth running
- A breaker roll increases deformation and improves results
- Manual or motorized adjustments of the rolls
- Opens for convenient maintenance

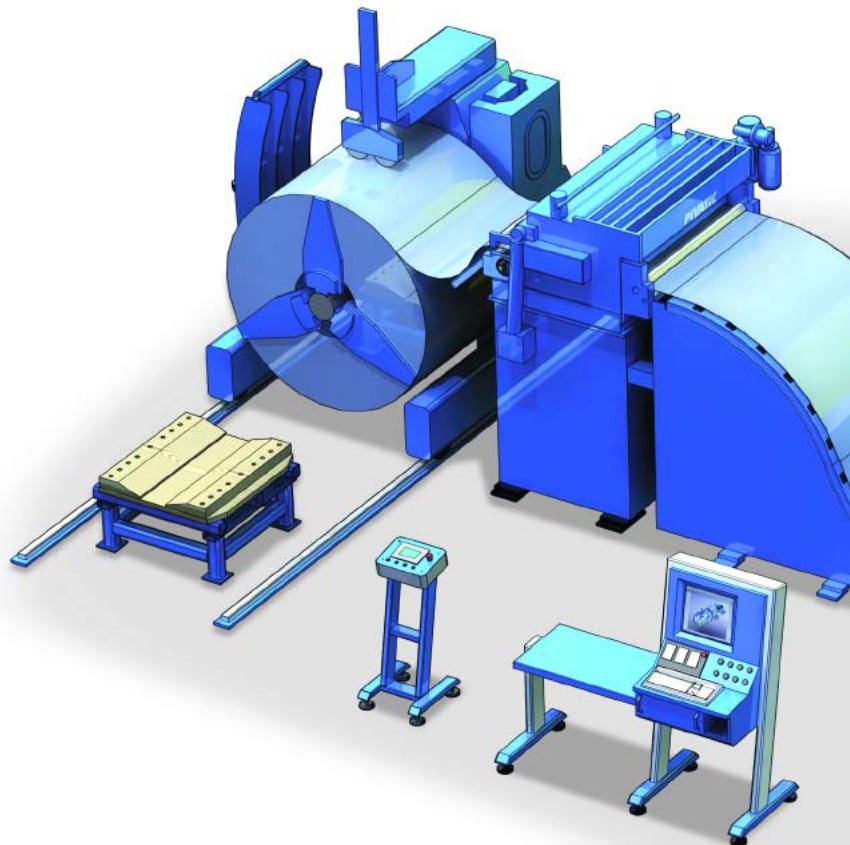
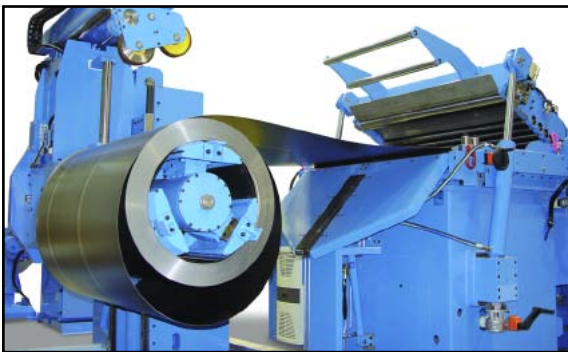

**All PivaPunch Centers come with a state-of-the-art numerical controller and PLC.**

Part programming, including nesting option, is carried out using PivaCam software straight from CAD files.



**PIVATIC**

An Ursviken Group Company

# a simple machine layout and it's advanced technology.



## At the heart of PivaPunch is a simple tool cassette.

Rather than being built to rotate and move great distances between each punch, the tool cassettes are built to move as little as possible. It moves only in the Y-axis over the sheet metal. The sheet metal, in its turn, moves only in the x-axis. Punching stations come standard with two tool cassettes, one on each side of the sheet. This simple design makes it possible to work several times faster than any other system.

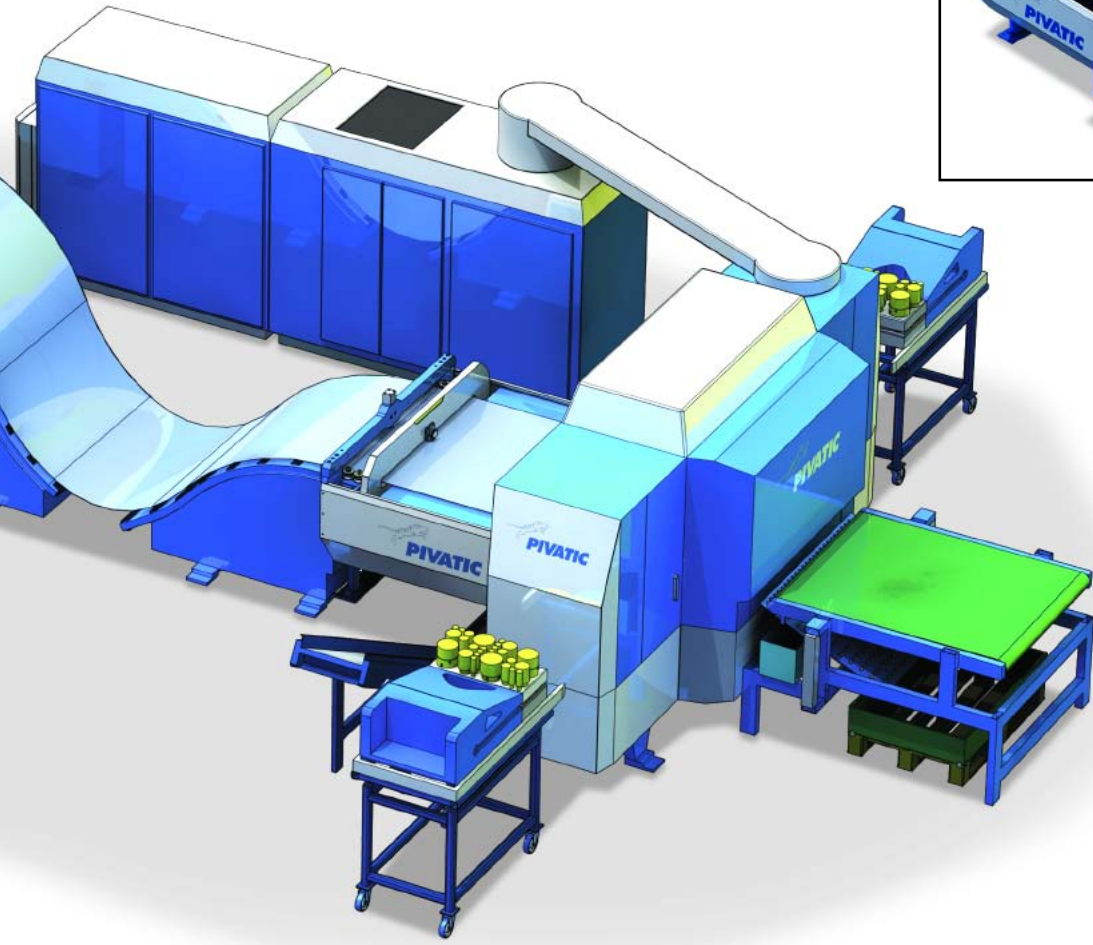
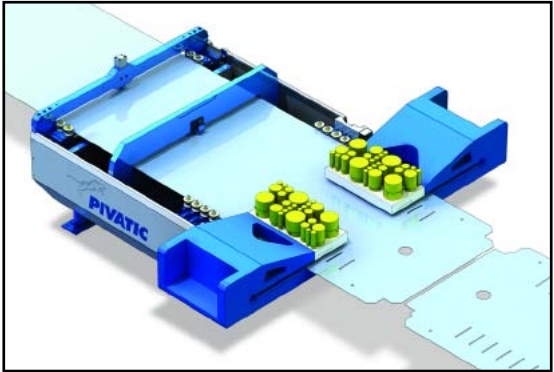

## PivaPunch cassette configuration offers many advantages.

Punching power is transmitted from the ram plate through striker pins driven by tool selectors to a tool in each tool cassette consecutively or at the same time when punching symmetrical patterns.

Pivatic's patented technology offers high hit rate, DTP (Double Tool Punch), two-tool-hit at the same time for symmetrical hole patterns, and programmable stroke and attachments for a variety of tool cassettes.

PivaPunch utilizes standard Thick Turret Tools that are available from suppliers world wide.

# PivaPunch offers a variety of Quick-Change Tool

All tools in the tool cassettes are active at all times. When another cassette which takes only a few minutes to change.

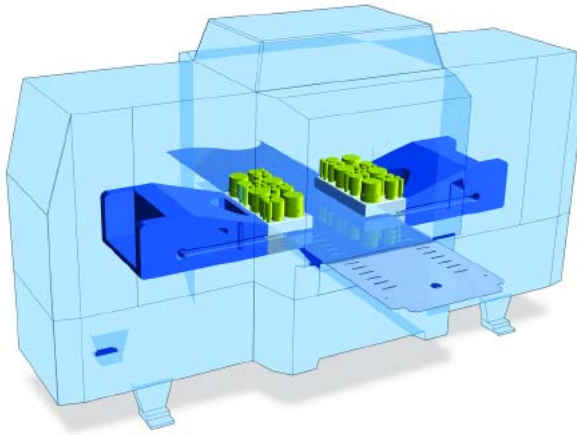

**PivaPunch concept allows for extremely short cycle times while keeping precise tolerances.**

The tool cassettes come in a variety of configurations making PivaPunch versatile and efficient for both simple and complex projects. As we proceed, you can see the most common tool cassette configurations.

**Stations A to F (.5" to 6" diameter) Thick Turret Tools can be set in the tool cassettes.**

The configuration of the tool cassettes determines what kind of tools the punching station can use and what kind of jobs it is capable of executing.

Color Code	Diameter up to
•	A Ø 0.500" Ø 12.7 mm
●	B Ø 1.250" Ø 31.8 mm
●	C Ø 2.000" Ø 50.8 mm
●	D Ø 3.500" Ø 88.9 mm
●	E Ø 4.500" Ø 114.3 mm
●	F Ø 6.000" Ø 152.4 mm

## Tool cassettes for punching stations TT & TTi

**PivaPunch Centers are versatile because the Quick-Change Tool Cassettes are made for:**

- Greater number of tools
- Tools of different sizes
- Fixed tools
- Auto-indexed tools



Tool Cassette TT is configured for 26 fixed tools: 12 A, 6 B, 4 C, 2 D and 2 E stations



Tool Cassette TTi is configured for 18 fixed tools and 1 auto-indexing tool: 10 A, 4 B, 2 C, 1 D and 1 E fixed stations and 1 indexing D station.

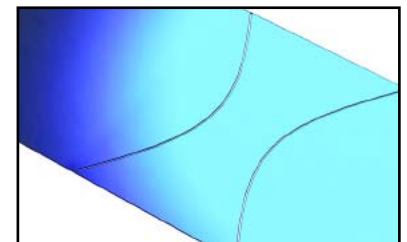
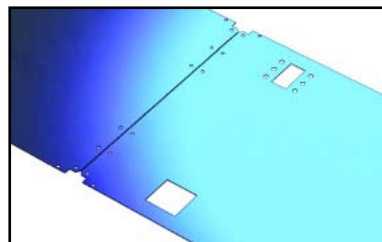
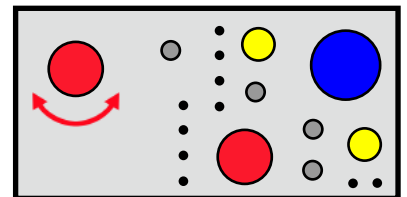
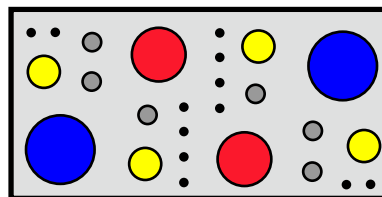

# Cassettes for each type of punching station.

a project needs a separate set of tools, these tools are set-up in Pivatic offers an expanded line of tool cassettes and special tools.

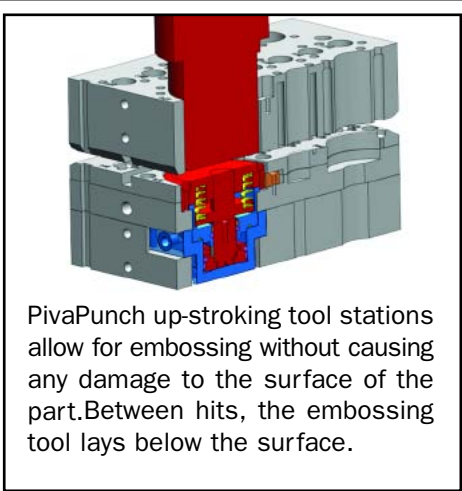

PivaPunch up-stroking tool stations allow for embossing without causing any damage to the surface of the part. Between hits, the embossing tool lays below the surface.

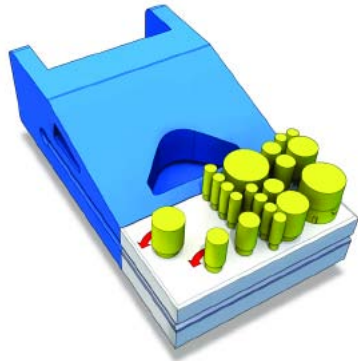

Tool cassette TTii is configured for 18 fixed tools and 2 auto-indexing tools: 10 A, 4B, 2C, 1D and 1E fixed and 1 indexing B and C station.

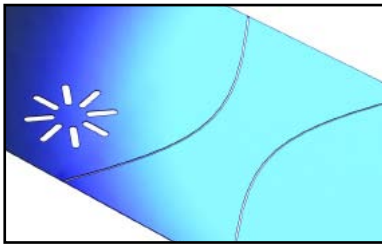
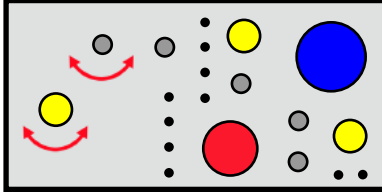

## Tool cassettes for punching station LT (Large Thick Turret Tools for CNC punching)

PivaPunch LT punching offer the capability of large standard tools and dedicated tools for CNC punching:

- Corner notching, standard hole patterns
- Trimming of strip to run more from the same coil
- Slitting of parts nested beside each other



Tool cassette LTT for versatile jobs including 2 F-Station tools.

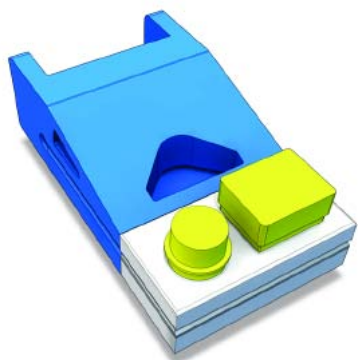
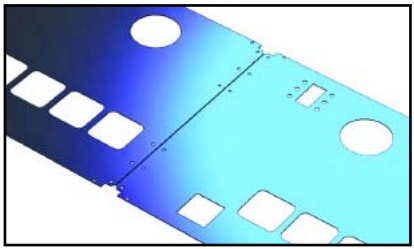
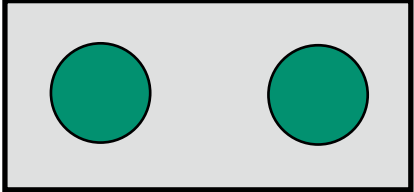

Tool cassette LTD including 1 F-station tool and 1 dedicated tool up to 200\*225 mm (7.87\*8.85"), gap 225 mm (8.85").

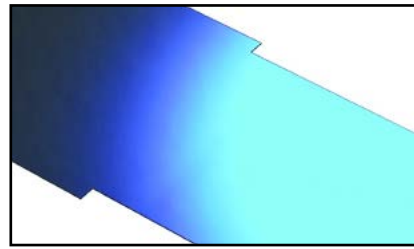
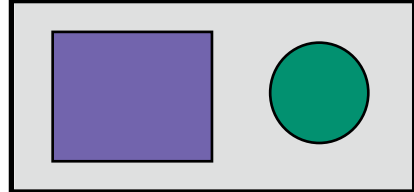

**The combination of two punching stations placed in a row increases both versatility and production speed for more complex projects.**

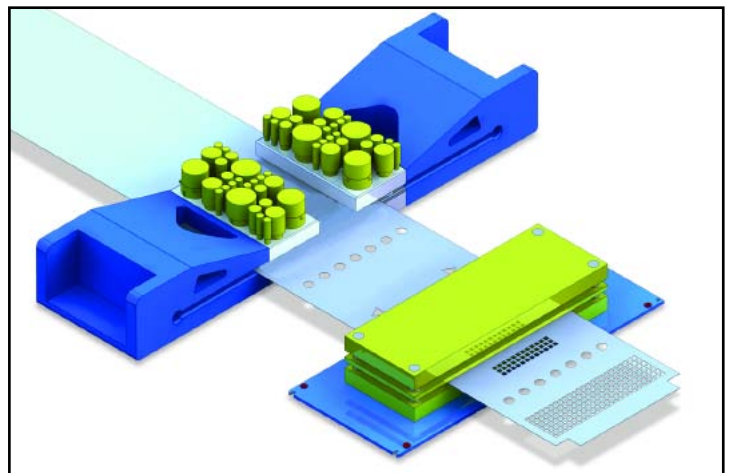
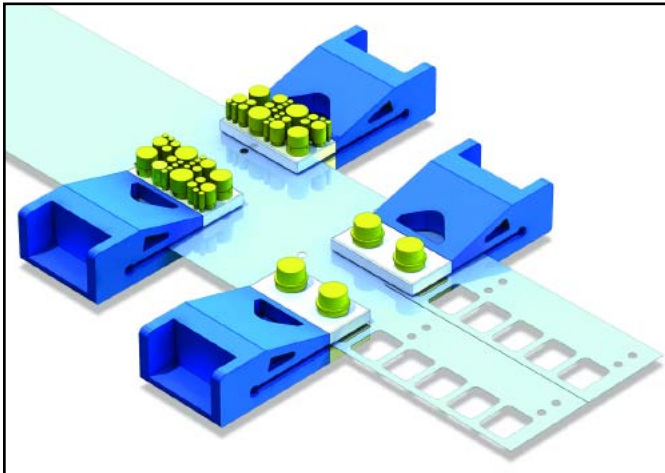

**Combination of TT station and LT station offers large Thick Turret Tool capacity:**

- CNC punched parts, hole groups, embossings, slitting and trimming
- CNC Coil Punch also for large tools up to 6" diameter
- Thick Turret type and dedicated tooling for trimming and notching

**Combination of TT and HT Stations for freely programmable punch and dedicated press tool capability.**

- CNC punched parts, perforation, large cut-outs & forms
- CNC coil punch and press tool capabilities
- Cycle times affected by tooling selection

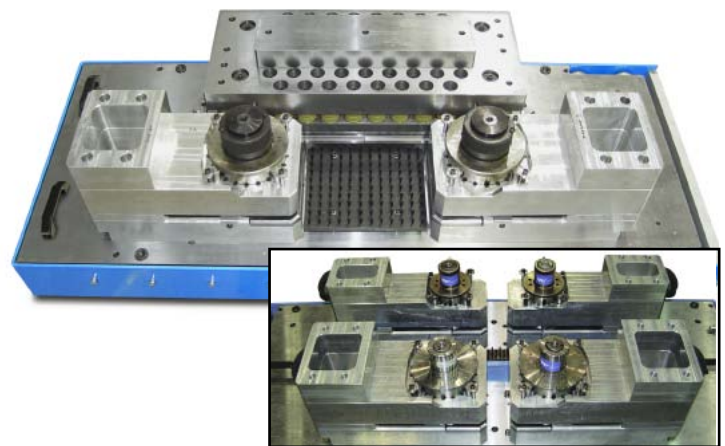
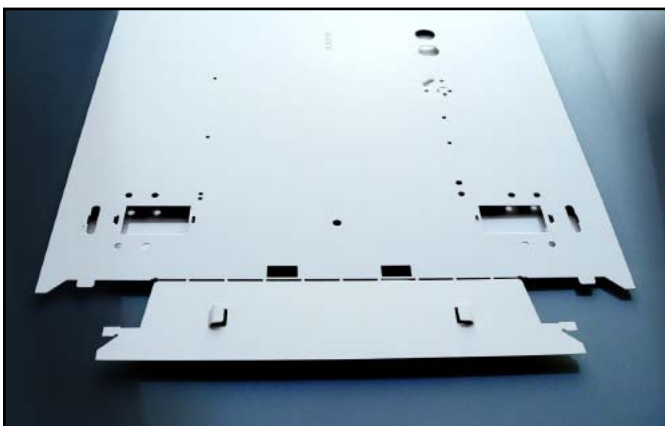



**PivaPunch PCC60**  
**Pivapunch centers for narrow coils**

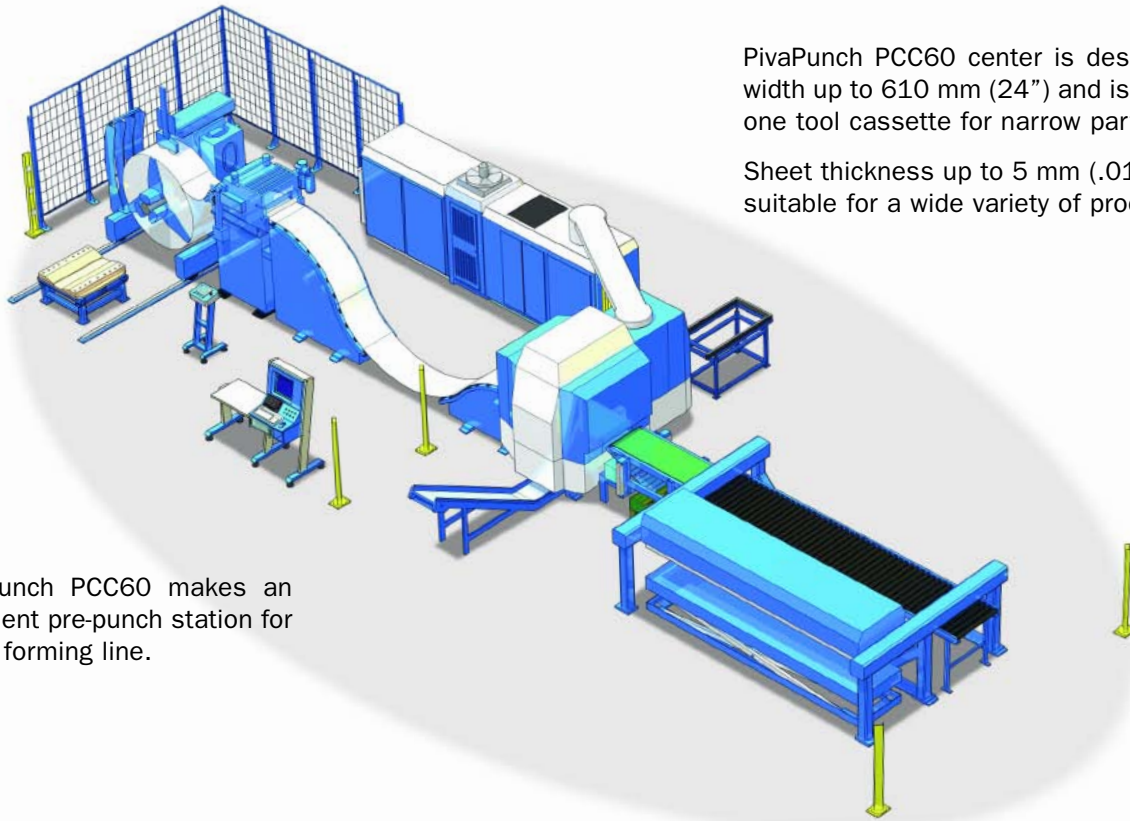

PivaPunch PCC60 center is designed for strip width up to 610 mm (24”) and is equipped with one tool cassette for narrow parts.

Sheet thickness up to 5 mm (.0197”) makes it suitable for a wide variety of products.

PivaPunch PCC60 makes an excellent pre-punch station for a roll forming line.

**PivaPunch Specifications**

Type	Strip Width		Sheet Thickness		Punching Stations Available				Trim & Notch	Stacker	
	mm	Inches	mm	inches	Type TT	Type TTi	Type LT	Type HT		Standard Blank Lengths	
										mm	inches
PCC60	60...610mm	2.36...24 inches	0,5..2	.019 ... .078	One Tool Cassettes	One Tool Cassettes				2250, 3000, 5000mm	89, 118, 197 inches
			0,5..5	.019 ... .196	One Tool Cassettes	One Tool Cassettes				2250, 3000, 5000mm	89, 118, 197 inches
PCC60	60...610mm	2.36...24 inches	0,5..2	.019 ... .078	Two Tool Cassettes	Two Tool Cassettes	X	X	X	2250, 3000, 5000mm	89, 118, 197 inches
			0,5..5	.019 ... .196	Two Tool Cassettes	Two Tool Cassettes	X	X		2250, 3000, 5000mm	89, 118, 197 inches
PCC80	60...815mm	2.36...32 inches	0,5..2	.019 ... .078	Two Tool Cassettes	Two Tool Cassettes	X	X	X	2250, 3000, 5000mm	89, 118, 197 inches
			0,5..4	.019 ... .157	Two Tool Cassettes	Two Tool Cassettes	X	X		2250, 3000, 5000mm	89, 118, 197 inches
PCC100	60...1016mm	2.36...40 inches	0,5..2	.019 ... .078	Two Tool Cassettes	Two Tool Cassettes	X	X	X	2250, 3000, 5000mm	89, 118, 197 inches
			0,5..4	.019 ... .157	Two Tool Cassettes	Two Tool Cassettes	X	X		2250, 3000, 5000mm	89, 118, 197 inches
PCC125	60...1250mm	2.36...49 inches	0,5..2	.019 ... .078	Two Tool Cassettes	Two Tool Cassettes	X	X	X	2250, 3000, 5000mm	89, 118, 197 inches
			0,5..3,5	.019 ... .137	Two Tool Cassettes	Two Tool Cassettes	X	X		2250, 3000, 5000mm	89, 118, 197 inches
PCC150	60...1525mm	2.36...60 inches	0,5..2	.019 ... .078	Two Tool Cassettes	Two Tool Cassettes	X	X	X	2250, 3000, 5000mm	89, 118, 197 inches
			0,5..3	.019 ... .118	Two Tool Cassettes	Two Tool Cassettes	X	X		2250, 3000, 5000mm	89, 118, 197 inches

Sheet Thickness (Material strength 400 N/mm<sup>2</sup>)



# PivaPunch – The most efficient and versatile

Your PivaPunch can be delivered either in the

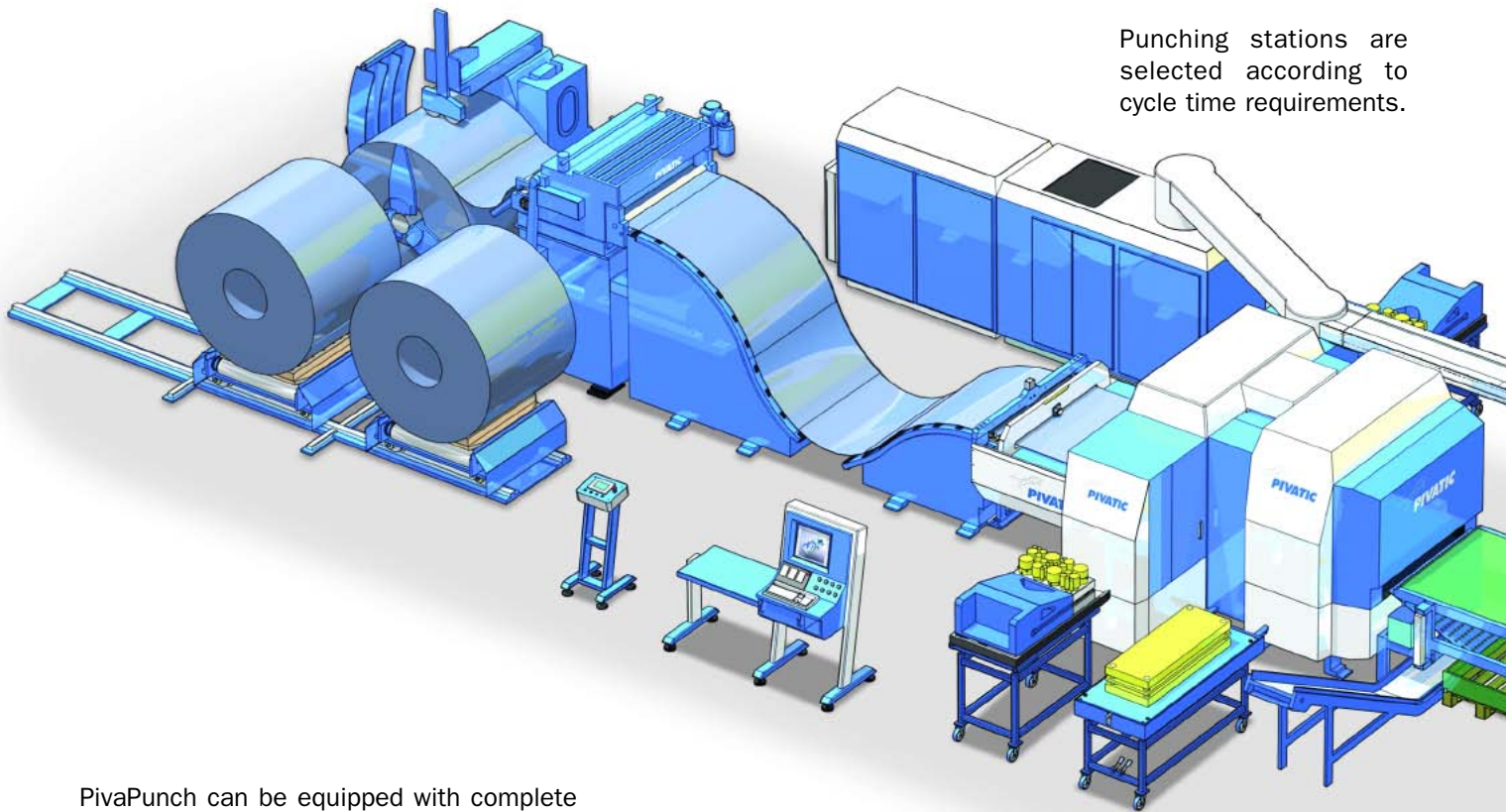

Punching stations are selected according to cycle time requirements.

PivaPunch can be equipped with complete material handling systems for feeding of coils and with stacking options for punched blanks. Two coil cars make it possible to change coils in minimal time.

Pivatic's software is developed in cooperation with the hardware to optimize efficiency. Pivatic's software is supported globally.



Use a multi station coil storage with coil cars when longer independent production comes to play.

# Coil Punch customized to your needs.

basic configuration or equipped to your special needs.



Trim and Notch Station adds flexibility and production speed.

- Part families with different widths run from the same coil
- Reduces the number of different coils and set-ups.
- Rectangular corners and cut-outs on the edges that are CNC punched
- Cycle times are reduced since Trim & Notch after Cutting-to-Length is a separate operation.

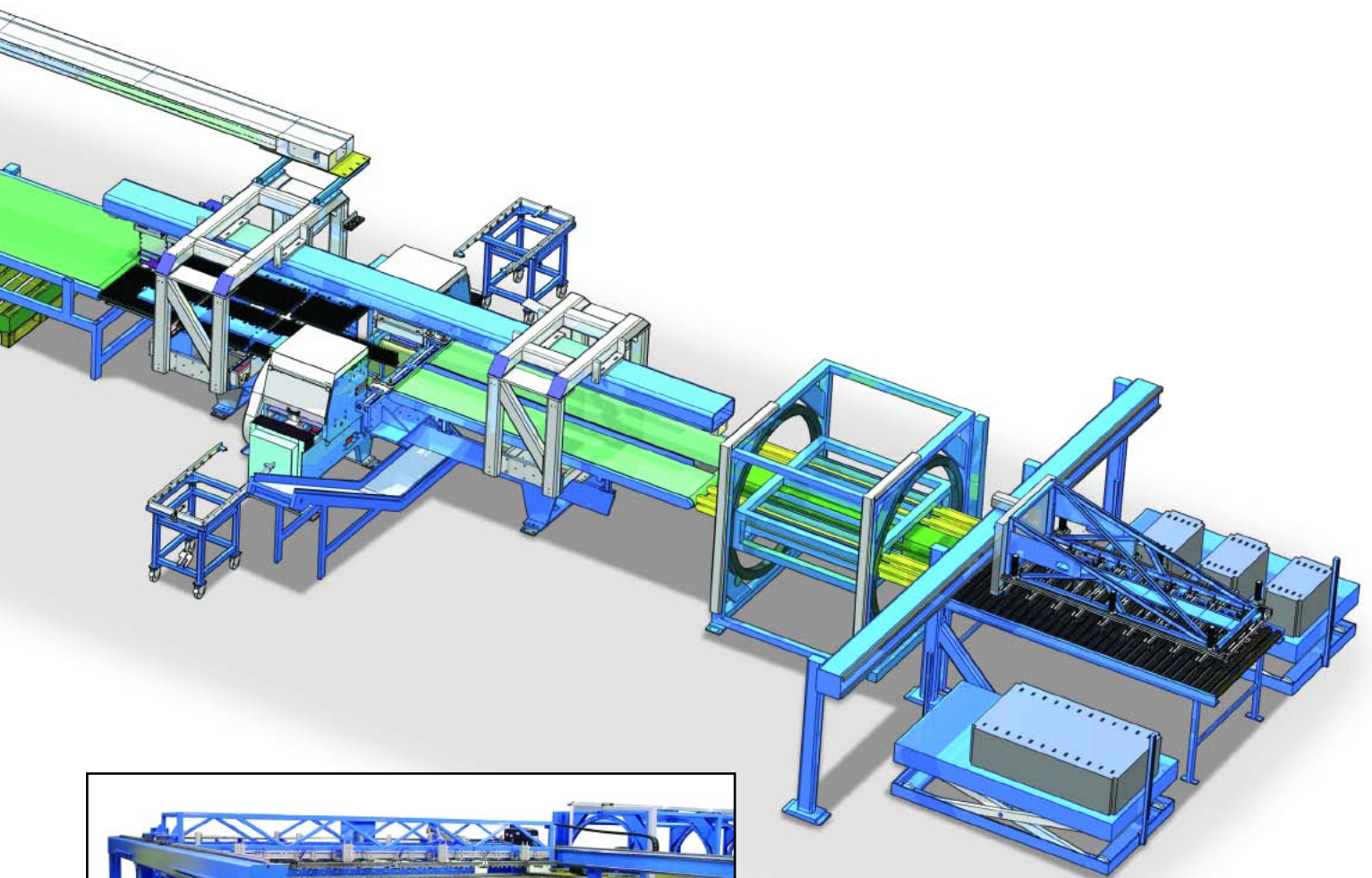

Blanks are piled on one or several lifting tables using the pick & place stacker. The entire area of the pallets can be utilized for stacking in several piles.

**Ursviken Group empowers productivity in sheet metal fabrication.**

The Ursviken Group is a global provider of high-end solutions for sheet metal manufacturers. We base our service and solutions on more than 100 years of being on the forefront of the metal forming industry. Our solutions are at the top of today's industry and give our customers a leap in productivity that leads to a healthy return on their investments.

The Ursviken Group consists of two leading companies, Pivatic Oy and Ursviken Technology AB. The Finish company Pivatic is a pioneer in manufacturing solutions based on coil. Ursviken is a Swedish company specializing in heavy plate metal working.



**In Scandinavia:**

**Pivatic Oy**

Varastokatu 8  
FI-05800 Hyvinkää  
Finland  
Tel: +358 19 427 4000  
Fax: +358 19 427 4099  
info@pivatic.com  
www.pivatic.com

**Ursviken Technology AB**

Mekanvägen 71  
SE-932 82 URSVIKEN  
Sweden  
Tel: +910 516 00  
Fax: +910 516 80  
info@ursviken.com  
www.ursviken.com

**In the USA:**

**Ursviken Inc.**

1636 Todd Farm Drive  
Elgin, IL 60123  
USA  
Tel: (866) 872-4868  
Fax: (847) 214-8705  
machinesales@ursviken.com  
www.ursviken.com



**PIVATIC**

An Ursviken Group Company